

Airplanes

Objectives:

In this unit you will learn

- Basics about the plane
- Relevant technical terms and their concepts
- Technical English: Classification

Text A Types of Airplanes

I Pre-Reading Task

Look at the following planes and see if you can classify them. The airplanes can be divided into different categories according to _____.

- (1) Airbus 320
- (2) B-2 Stealth Bomber
- (3) Tractor AT-802A
- (4) Diamond DA42
- (5) Boeing 747
- (6) E-6 (Mercury)
- (7) Blackhawk
- (8) F-22 (Raptor)
- (9) C-130 (Hercules)
- (10) Unmanned Global Hawk
- (11) X-38
- (12) ICON 5A



II While-Reading Task

Guess the meaning of each italicized word or phrase in the text and put it down in Chinese in the corresponding blank.

<p>1 How many types of airplanes are there?</p> <p>2 Airplanes vary greatly in size, structure, engines, and purpose. It is hard to give a satisfactory answer without further clarification of the question. There are a lot of different types of airplanes, and it's because there are a lot of different jobs for airplanes to do. The following classification is one answer you may expect in most cases.</p> <p>3 Modern airplanes can be divided into five main types:</p> <p>(1) commercial transport planes, (2) general aviation planes, (3) military planes, (4) sea planes, (5) special purpose planes.</p> <p>4 Commercial transport planes (also called airliners) are large planes used for carrying passengers and sometimes cargo.</p> <p>5 Four-engine jets are more powerful than most airliners. That's because most airliners only travel 500 to 600 miles per hour (805 to 966 kilometers per hour), and four-engine jets can travel faster and farther. The Boeing 747^[1] is a four-engine jet which can carry more than 400 passengers, six <i>galley</i>s, twelve washrooms, and more than 47,000 gallons (178,000 liters) of fuel. This airliner can fly 6,495 miles (10,475 kilometers) non-stop. That's farther than the distance between New York (USA) City and Tokyo(Japan). The Airbus 380^[2] is also a four-engine jet airliner which provides seating for 525 people in a typical three-class <u>configuration</u> or up to 853 people in all-economy class configurations. The A380-800 has a design range of 15,400 kilometers, sufficient to fly from New York City to Hong Kong(China), and a cruising speed of Mach 0.85 (about 900 kilometers per hour or 560 miles per hour at <i>cruising altitude</i>).</p> <p>6 There are also three-engine jets and twin-engine jets. As you probably can imagine, three-engine jets don't travel as far as four-engine jets and need less runway to take-off and land. But some three-engine jets can carry as many passengers as four-engine jets. Twin-engine jets are smaller than four or three-engine jets. 90% of airliners today are twin-engine jets.</p>	<p>Word Tips & Meaning Guessing</p> <p>_____ (Guess)</p> <p><i>n.</i> 布局; 格局</p> <p>_____ (Guess)</p>
--	--



7 Why do you think twin-engine jets are used the most?

8 General aviation plane is one of the two categories of civil aviation. It refers to all flights other than military and scheduled airline and regular cargo flights, both private and commercial. Most general aviation planes have two to six seats, and one engine. General aviation planes are used for many purposes. Sometimes people use them to teach students how to fly a plane, or they are used to take pictures from a high-up view; sometimes people use them for transportation, and sometimes people use them for enjoyment. Some farmers use them for planting seeds, checking soil erosion, and counting livestock. The Diamond DA20, for example, is a two-seat tricycle gear general aviation aircraft designed for flight training. In addition to its role as a civil and military training aircraft, it is also used for personal flying by pilot-owners.

9 Military planes are planes used by the military. Most military planes are used to attack enemies on the ground or in the air. Some military planes are used to carry equipment and soldiers to bases or battlefields. For example, F-22 *Raptor*, mainly developed by Lockheed Martin Aeronautics^[3], is a single-seat, twin-engine fifth-generation supermaneuverable fighter aircraft that uses *stealth technology*. It was designed primarily as an air superiority fighter, but has additional capabilities that include ground attack, electronic warfare, and signals intelligence roles.

10 Sea planes can be further divided into three types:

(1) *float planes*,

(2) flying boats,

(3) amphibians.

11 A floatplane (float plane or *pontoon* plane) has big floats instead of wheels, with one or more slender pontoons (known as “floats”) mounted under the fuselage to provide buoyancy. Only the floats of a floatplane normally come into contact with water. The *fuselage* remains above water. Some small land aircraft can be modified to become float planes, and in general floatplanes are small aircraft. Floatplanes are limited by their inability to handle wave heights typically greater than 12 inches (0.31 m). These floats add to the empty weight of the airplane, and to the *drag coefficient*, resulting in reduced payload capacity, slower rate-of-climb, and slower cruise speed.

n. 腐蚀; 侵蚀

_____ (Guess)

_____ (Guess)

_____ (Guess)

n. 水陆两用飞机

_____ (Guess)

n. 浮力

_____ (Guess)

_____ (Guess)



12 A flying boat is a fixed-winged seaplane with a hull allowing it to land on water. It differs from a float plane as it uses a purpose-designed fuselage which can float, granting the aircraft buoyancy. Flying boats may be stabilized by under-wing floats or by wing-like projections (called sponsons) from the fuselage. Their advantage lays in using water instead of expensive land-based runways, making them the basis for international airlines in the interwar period. They were also commonly used for maritime patrol and air-sea rescue.

n. 舷侧凸出部

13 An amphibious aircraft or amphibian is an aircraft that can take off and land on either land or water. Fixed-wing amphibious aircraft are seaplanes (flying boats and floatplanes) that are equipped with *retractable* wheels, at the expense of extra weight and complexity, plus diminished range and fuel economy compared to planes designed for land or water only. Some amphibians are fitted with reinforced *keels* which act as skis, allowing them to land on snow or ice with their wheels up and are dubbed *Tri-phenians*.

_____ (Guess)

v. 减少; 变小

_____ (Guess)

v. 起绰号

_____ (Guess)

14 Special purpose planes are made to carry out specific functions. They are used for specific tasks such as duty in natural disasters, spraying chemicals, and providing relief during emergency situations. Some amphibians also have a special purpose. They are used for putting out forest fires. They fly just above the lakes and ponds and suck up water which they can later spray on forest fires. An example of a special purpose plane is the Bombardier 415 Superscooper^[4] designed and built specifically for aerial firefighting. The 415 can scoop up to 6,140 litres (1,350 Imperial gal or 1,620 U.S. gal) of water from a nearby water source, mix it with a chemical foam if desired, and drop it on a fire without having to return to base to refill its tanks.

n. 赈灾物品

Notes

[1] Boeing 747 (波音 747) 是由波音公司研发的大型客机。

[2] Airbus 380 (空客 380) 是由欧洲 Airbus 公司研发的大型客机, 2007 年投入商业运行。

[3] Lockheed Martin Aeronautics (洛克希德-马丁公司) 是一个美国航空航天设备制造商。

[4] Bombardier 415 Superscooper 是一种有专门用途的水陆两用飞机, 主要用来完成空中灭火任务。



III Comprehension of Text A

1. Complete the following outline of the text by supplying the missing information.

Airplanes can be classified into _____ types:

- (1) Commercial transport planes used for _____;
- (2) _____ designed to destroy enemy equipment using their own armament;
- (3) Sea planes which can be divided into flying boat, _____ and _____;
- (4) _____ used for civil aviation;
- (5) _____ used for specific tasks.

2. Answer the following questions without referring back to the text.

- (1) Which type does a private plane belong to? Why?
- (2) How can an amphibian take off and land on either land or water?

IV Vocabulary Development

1. Translate into Chinese the following words or phrases from the text.

- (1) three-class configuration (Para. 5)
- (2) all-economy class configurations (Para. 5)
- (3) civil aviation (Para. 8)
- (4) soil erosion (Para. 8)
- (5) stealth technology (Para. 9)
- (6) signals intelligence (Para. 9)
- (7) electronic warfare (Para. 9)
- (8) payload capacity (Para. 11)
- (9) maritime patrol (Para.12)
- (10) aerial firefighting (Para.14)
- (11) chemical foam (Para. 14)

2. Complete each of the following sentences by filling in the blank with a word you select from the box. Change the form where necessary. (You can use a word from the box more than once.)

reinforce	retractable	superiority
amphibious	configuration	dub
diminish	mount	maritime
buoyancy	cruise	maneuverable

- (1) Their debts continued to _____ up.
- (2) DHCP is famous for its robust dynamic IP address _____ mechanism.



- (3) Do you have any statistics to _____ your argument?
- (4) A _____ device containing intake and exhaust pipes permits a submarine to stay submerged for extended periods of time.
- (5) Does this _____ package include any voyages to islands?
- (6) This is a fast _____ fighter plane designed to intercept enemy aircraft.
- (7) Nothing could _____ her enthusiasm for the project.
- (8) That has led some counselors to _____ them “chicken ribs”—tasteless when eaten but a pity to throw away.
- (9) _____ shipping is an important link in international logistics service.
- (10) The upward force of a liquid is called _____, which can keep some objects up.
- (11) The purpose of disarmament should be to _____, not weaken or undermine, the security of all countries.
- (12) The united opponent parties are getting ready to _____ a powerful attack on the government.
- (13) These species are widely located in various transitional terrestrial and _____ (amphibious) eco-systems.
- (14) Violent groups generally have overt belief systems that emphasize their _____ over others.
- (15) Helicopters from a carrier could provide support to potential _____ operations; fixed-wing aircraft operating from a carrier could provide greater air defense over a potential beachhead.

3. Aeronautical terms: Translate the following terms into Chinese. And then try to explain or define them in English.

- (1) cruising speed
- (2) cruising altitude
- (3) twin-engine jet
- (4) pontoon
- (5) fuselage
- (6) rate-of-climb
- (7) fixed-winged
- (8) float plane
- (9) drag coefficient
- (10) stealth technology

V Group Work

Questions for discussion.

- (1) Do you know the biggest airliner in the world? Tell your group members about it if you



do.

(2) What is the cutting edge technology now applied to the military aircraft development? Give some examples to your group.

Text B Airplane Components

I Pre-Reading Task

Try to write down the aeronautical term in each blank in Fig.1.1. And check your answers after reading Text B.

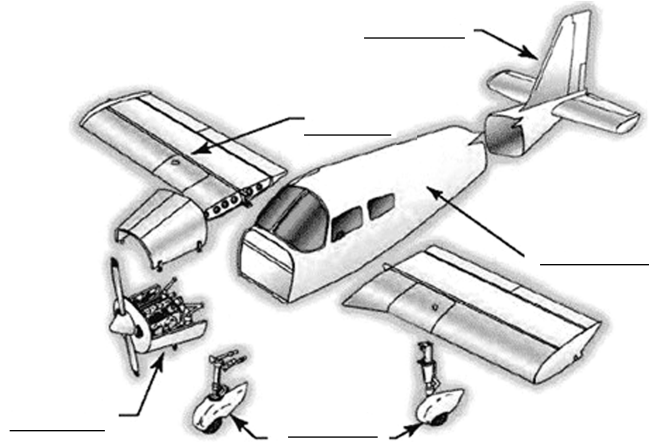

Fig.1.1

II While-Reading Task

Guess the meaning of each italicized word or phrase in the text and put it down in Chinese in the corresponding blank.

1 Airplanes come in many different shapes and sizes depending on the mission of the aircraft, but all modern airplanes have certain components in common. These are the fuselage, wing, tail assembly (technically called empennage) and control surfaces, landing gear, and powerplant(s).

2 For any airplane to fly, it must be able to lift the weight of the airplane, its fuel, the passengers, and the cargo. The wings generate most of the lift to hold the plane in the air. To generate lift, the airplane must be pushed through the air. The engines, which are usually located beneath the wings, provide the *thrust* to push the airplane forward through the air.

Word Tips & Meaning Guessing

n. 尾翼

_____ (Guess)



3 The fuselage is the body of the airplane that holds all the pieces of the aircraft together and many of other large components are attached to it. The fuselage is generally streamlined as much as possible to reduce *drag*. Designs for fuselages vary widely. Most modern aircraft use a form of the stressed skin structure known as monocoque or semimonocoque construction.

4 The monocoque design uses stressed skin to support almost all imposed loads. This structure can be very strong but cannot tolerate dents or deformation of the surface.

5 The semimonocoque system uses a substructure to which the airplane's skin is attached. The substructure, which consists of *bulkheads* and/or formers of various sizes and stringers, reinforces the stressed skin by taking some of the bending stress from the fuselage.

6 The fuselage houses the *cockpit* where the pilot and flight crew sit and provides areas for passengers and cargo. It may also carry armaments of various sorts. Some aircraft carry fuel in the fuselage; others carry the fuel in the wings. In addition, an engine may be housed in the fuselage.

7 There are numerous wing designs, sizes, and shapes used by the various manufacturers. Each fulfills a certain need with respect to the expected performance for the particular airplane. The wing provides the principal lifting force of an airplane. Lift is obtained from the dynamic action of the wing with respect to the air. The cross-sectional shape of the wing as viewed from the side is known as the *airfoil section*. The planform shape of the wing (the shape of the wing as viewed from above) and placement of the wing on the fuselage (including the angle of incidence), as well as the airfoil section shape, depend upon the airplane mission and the best compromise necessary in the overall airplane design.

8 In most modern airplanes, the fuel tanks either are an integral part of the wing's structure, or consist of flexible containers mounted inside of the wing.

9 The control surfaces include all those moving surfaces of an airplane used for *attitude*, lift, and drag control. They include the tail assembly (empennage), the structures at the rear of the airplane that serve to control and maneuver the aircraft, and structures forming part of and attached to the wing.

_____ (Guess)

n. 单壳

_____ (Guess)

n. 纵梁; 桁条

_____ (Guess)

_____ (Guess)

机翼安装角

_____ (Guess)



10 The tail usually has a fixed horizontal piece (called the horizontal stabilizer) and a fixed vertical piece (called the *vertical stabilizer*). The stabilizers provide stability for the aircraft—they keep it flying straight. The vertical stabilizer keeps the nose of the plane from swinging from side to side (called yaw), while the horizontal stabilizer prevents an up-and-down motion of the nose (called *pitch*). (On the Wright brothers’^[1] first successful aircraft, the horizontal stabilizer was placed in front of the wings. Such a configuration is called a canard after the French word for “duck”).

11 The hinged part found on the trailing edge of the wing is called the aileron. It is used to roll the wings from side to side. Flaps are hinged or pivoted parts of the leading and/or trailing edges of the wing used to increase lift at reduced airspeeds, primarily at landing and takeoff. Spoilers are devices used to disrupt the airflow over the wing so as to reduce the lift on an airplane wing quickly. By operating independently on each wing, they may provide an alternate form of roll control. Slats at the front part of the wing are used at takeoff and landing to produce additional lift.

12 At the rear of both the aileron surfaces of elevators and rudders are small moving sections called trim tabs that are attached by hinges. Their function is to (1) balance the airplane if it is too nose heavy, tail heavy, or wing heavy to fly in a stable cruise condition; (2) maintain the *elevator*, rudder, and ailerons at whatever setting the pilot wishes without the pilot maintaining pressure on the controls; and (3) help move the elevators, rudder, and ailerons and thus relieve the pilot of the effort necessary to move the surfaces.

13 The landing gear, or undercarriage, supports the airplane when it is resting on the ground or in water and during the takeoff and landing. The gear may be fixed or retractable. The wheels of most airplanes are attached to shock-absorbing struts that use oil or air to cushion the blow of landing. Special types of landing gear include skis for snow and floats for water. For carrier landings, arrester hooks are used.

14 Forward motion, or thrust, is generated by a thrust-producing device or powerplant to sustain flight. The powerplant consists of the engine (and propeller, if present) and the related accessories. The main engine types are the reciprocating (or piston type), and the reaction, or

水平尾翼

_____ (Guess)

n. 偏航；测滑

_____ (Guess)

n. 鸭式气动布局

n. 副翼；襟翼

n. 阻流片

n. 前缘缝翼

n. 方向舵调整片

_____ (Guess)

n. 支柱；撑杆



jet engine. The propeller converts the energy of a reciprocating engine's rotating crankshaft into a thrust force. Usually the engines are located in *cowled pods* hung beneath the wings, but some aircraft, like fighter aircraft, will have the engines buried in the fuselage.

15 Other configurations have sometime been used. For instance, the Wright brothers' 1903 Flyer had pusher propellers (propellers at the rear of the plane) and the elevators at the front of the aircraft. Many fighter aircraft also combine the horizontal stabilizer and elevator into a single stabilator surface. There are many possible aircraft configurations, but any configuration must provide for the four forces—weight, lift, drag, and thrust—needed for flight.

_____ (Guess)

Notes

[1] Wright brothers (莱特兄弟), 威尔伯·莱特 (Wilber Wright) 生于 1867 年 4 月 16 日。他的弟弟奥维尔·莱特 (Orville Wright) 生于 1871 年 8 月 19 日。他们从小就对机械装配和飞行怀有浓厚的兴趣, 从事自行车修理和制造行业。他们在 1903 年制造出了第一架依靠自身动力进行载人飞行的飞机——“飞行者”1 号。这架飞机的翼展为 13.2m, 升降舵在前, 方向舵在后, 两副两叶推进螺旋桨由链条传动, 着陆装置为滑橇式, 装有一台 70kg 重、功率为 8.8kW 的四缸发动机。这架航空史上著名的飞机, 现在陈列在美国华盛顿航空航天博物馆内。

III Comprehension of Text B

1. Fill in each blank in Fig.1.2 with the aeronautical term according to the description in the text.

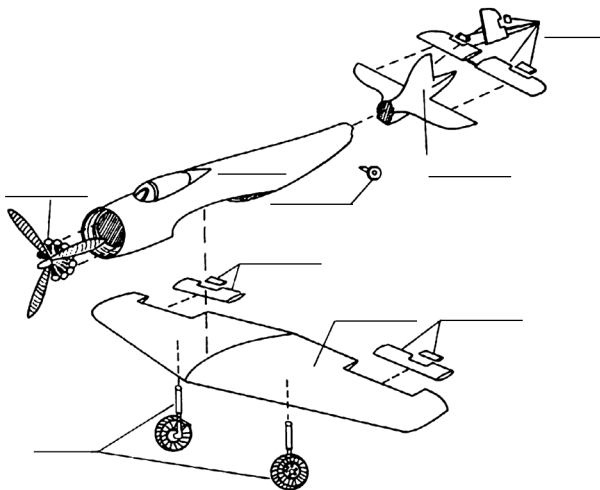

Fig.1.2



2. Write down the technical term in each blank for the part in Fig.1.3. Please check your answer against the corresponding paragraphs in the text.

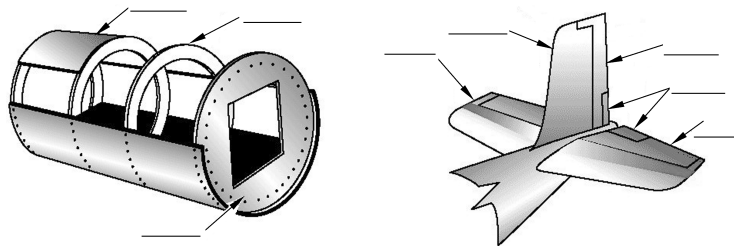

Fig.1.3

3. List the relevant terms under each major component of an airplane discussed in the text.

- (1) empennage (tail assembly): _____
- (2) fuselage: _____
- (3) wing: _____
- (4) landing gear: _____
- (5) powerplant: _____

IV Technical English

1. Classification.

Classification is a basic technique in organization. It starts with the recognition that different items have similar characteristics and develops with the sorting of these items into related groups. Any group of items plural in meaning may be classified. These items can be objects, processes or concepts. Men's jacket, for example, can be classified by fabric, style, size, color, etc. Vehicles is usually divided into the categories in Fig.1.4.

Concepts or ideas, such as the causes of obesity in the U. S., may make use of the principles of classification; the causes may be classified according to diet, physical exercise, genes, overall lifestyle, etc.

The categories in a classification system must be coordinate, mutually exclusive, non-overlapping, and complete. A classification system must have all of these qualities if it is adequate.

Now look at the following examples and decide whether the categories have these qualities or not:

- (1) The fabrics in a sewing shop is classified as *natural fiber, synthetics, or blend*;
- (2) Automobile tires are classified as *whitewall, blackwall, red stripe and tubeless*;
- (3) Automobiles are classified, according to source of power, into *gas, diesel, electric, and solar*.

The categories, or classes, in a classification system should be presented in the order that will best help to accomplish your purpose. In classifying steps in a process, probably a chronological, or time, order would be used. In classifying the qualities a pilot should have, the

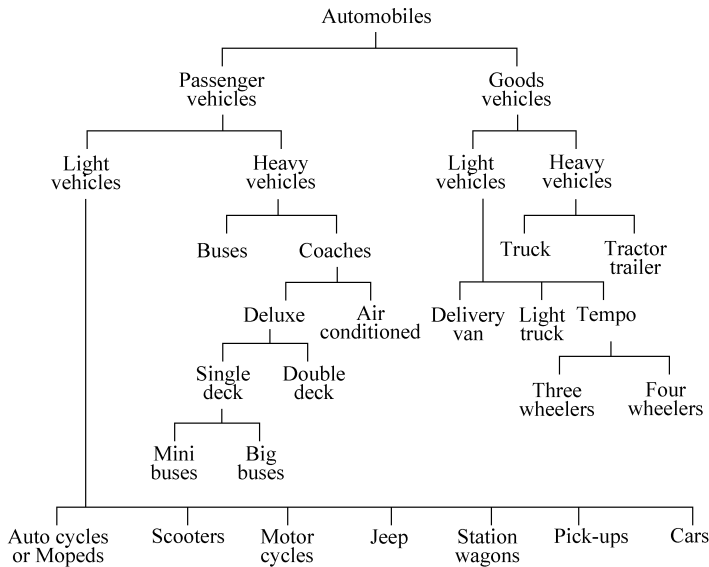

Fig.1.4

qualities might be listed in order of importance. A spatial order, movement from one physical point to another (from left to right, from top to bottom, etc.) may be the most practical arrangement as in classifying the parts of an airplane or the furnishings in a house. Also used in the presentation of categories are an order of familiarity, an alphabetical order, a random order and order according to complexity.

2. Other ways of classification of airplanes.

We can see from Text A, airplanes can be divided into different types according to their sizes, engines, structures, and purposes. Now you may try to name some according to the way of classification suggested in the following exercise.

Divide again airplanes into categories according to the following bases.

- (1) The airplane that flies using different sources of power: _____;
- (2) The aircraft that has no engine (using the energy of the air): _____;
- (3) The plane whose main rotor provides lift and propulsion: _____;
- (4) The aircraft whose main (top) rotor provides lift only; another method of thrust is required to push it forward: _____.

V Group Work

Questions for discussion.

- (1) In a group of four or five students, orally explain in turn each major aircraft part with some illustrations.
- (2) Classify satellites in as many ways as you know.

Aircraft Engines

Objectives:

In this unit you will learn

- Basics of aircraft engines
- Relevant technical terms and their concepts
- Technical English: Description of a mechanism (1)

Text A Aircraft Engines

I Pre-Reading Task

Look at the following planes (Fig. 2.1) and see if you can figure out what type of engines they are equipped with.



1. _____

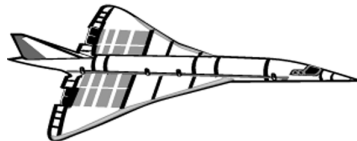

2. _____



3. _____



4. _____

Fig. 2.1



II While-Reading Task

Guess the meaning of each italicized word or phrase in the text and put it down in Chinese in the corresponding blank.

	Word Tips & Meaning Guessing
<p>1 Ever since Wilber and Orville^[1] flew over the sands of North Carolina, aircraft designers have been trying different types of airplane engines. The purpose of airplane engines is to provide thrust to push an aircraft through the air and overcome the force of drag. Designers are concerned with the amount of power or thrust produced, the weight of the engines, fuel consumption, and the cost.</p>	
<p>2 From 1903 to the late 1930s the gas powered <i>reciprocating internal-combustion engine</i> with a propeller was the sole means used to propel aircraft.</p>	<p>_____ (Guess)</p>
<p>3 Piston aircraft engines reached their <i>zenith</i> during World War II. Aircraft developed for the war were added <i>superchargers</i> and were able to fly higher and faster than any planes did in history.</p>	<p>_____ (Guess) _____ (Guess)</p>
<p>4 Reciprocating aircraft engines can be either water-cooled or air-cooled. Liquid-cooled engines can be built in any configuration, such as <i>in-line cylinders</i>, V configurations, or flat opposing cylinders. Historically, air-cooled engines were in a radial configuration so all of the cylinders can cool equally. Modern, general aviation engines are usually air-cooled in a horizontally opposed cylinder configuration.</p>	<p>_____ (Guess)</p>
<p>5 The use of piston engines in modern aircraft is mostly limited to private single and twin engine aircraft. Piston engines in private aircraft are efficient and less expensive to buy and maintain. The technology in these engines keeps improving to allow the use of <i>alternate fuels</i> and to add advanced electronic engine management.</p>	<p>_____ (Guess)</p>
<p>6 It was Frank Whittle, a British pilot, who designed the first <i>turbojet engine</i> in 1930. The first Whittle engine successfully flew in April, 1937. This engine featured a multistage compressor, and a <i>combustion chamber</i>, a single stage turbine and a <u>nozzle</u>.</p>	<p>_____ (Guess)</p>
<p>7 The first jet airplane to successfully use this type of engine was the German Heinkel He 178^[2]. It was the world's first turbojet powered flight. General Electric built the first American jet plane for the U.S. Army Air Force. It was the XP-59A^[3] experimental aircraft.</p>	<p>_____ (Guess) n. 喷嘴, 喷口</p>



8 The use of jet engines in aircraft became widespread in the 1950s and now almost all commercial and military aircrafts are powered by jet engines. Jet engines are turbine engines and allow airplanes to fly higher and faster.

9 The term “jet engine” is often used as a generic name for a variety of engines. These engines all operate by the same basic principles, but each has its own distinct advantages and disadvantages.

10 The key to making a jet engine work is the compression of the incoming air. If uncompressed, the air-fuel mixture won't burn and the engine can't generate any thrust. Most members of the jet family employ a section of compressors, consisting of *rotating blades*, that slow the incoming air to create a high pressure. This compressed air is then forced into a combustion section where it is mixed with fuel and burned. As the high-pressure gases are exhausted, they are passed through a turbine section consisting of more rotating blades. In this region, the exhausting gases turn the turbine blades which are connected by a shaft to the compressor blades at the front of the engine. Thus, the exhaust turns the turbines which turn the compressors to bring in more air and keep the engine going. The combustion gases then continue to expand out through the nozzle creating a forward thrust. The above explanation describes a simple turbojet, as illustrated in Fig. 2.2.

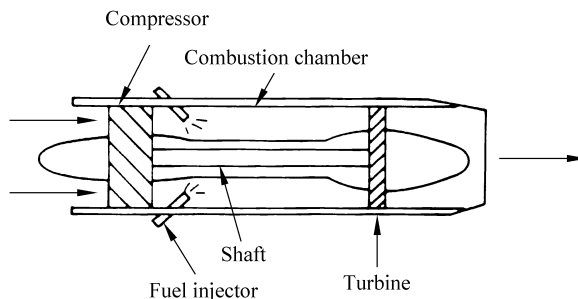

Fig. 2.2

11 The turbojet (and the turbofan) can also be fitted with an *afterburner*. An afterburner is simply a long tube placed in between the turbine and the nozzle in which additional fuel is added and burned to provide a significant boost in thrust. However, afterburners greatly increase fuel consumption, so aircraft can only use them for brief periods.

_____ (Guess)

n. 轴, 杆

_____ (Guess)



12 A further variation on the turbojet is the *turbofan*. Although most components remain the same, the turbofan introduces a fan section in front of the compressors. The fan, another rotating series of blades, is also driven by the turbine, but its primary purpose is to force a large volume of air through outer ducts that go around the engine core. Although this “bypassed” air flow travels at much lower speeds, the large mass of air that is accelerated by the fan produces a significant thrust (in addition to that created by the turbojet core) without burning any additional fuel. Thus, the turbofan is much more fuel efficient than the turbojet.

13 Turbofans are typically broken into one of two categories—low-bypass ratio and high-bypass ratio. The bypass ratio refers to the ratio of incoming air that passes through the fan ducts compared to the incoming air passing through the jet core. In a low-bypass turbofan, only a small amount of air passes through the fan ducts and the fan is of very small diameter. The fan in a high-bypass turbofan is much larger to force a large volume of air through the ducts. The low-bypass turbofan is more compact, but the high-bypass turbofan can produce much greater thrust, is more fuel efficient, and is much quieter.

14 A concept similar to the turbofan is the *turboprop*. However, instead of the turbine driving a ducted fan, it drives a completely external propeller. Turboprops are commonly used on commuter aircraft and long-range planes that require great endurance like the P-3 Orion and Tu-95^[4].

15 The turboprop is attractive in these applications because of its high fuel efficiency, even greater than the turbofan. However, the noise and vibration produced by the propeller is a significant drawback, and the turboprop is limited to subsonic flight only. In a typical turboprop, the jet core produces about 15% of the thrust while the propeller generates the remaining 85%.

16 Another noteworthy variation on the turbojet is the ramjet. The idea behind this type of engine is to remove all the rotary components of the engine (i.e., fans, compressors, and turbines) and allow the motion of the engine itself to compress incoming air for combustion.

17 However, the price of this simplicity is that the ramjet can only produce thrust when it is already in motion. Instead of using a

(Guess)

n. 通道, 风道

(Guess)

n. 螺旋桨

n. 冲压喷气(发动机)



compressor to draw in air and compress it for combustion, the ramjet relies on the motion of the aircraft to ram air into the engine at high enough speed that the air is already sufficiently compressed for combustion to occur. Since ramjets typically cannot function until reaching about 300 mph (485 km/h) at sea level, they have been rarely used on manned aircraft. However, the ramjet is more fuel efficient than turbojets or turboprops starting at about 3 Mach making them very attractive for use on missiles.

18 The *turboshaft* is a version of the jet engine that powers nearly every helicopter built today. The turboshaft utilizes many of the same components as a turbojet. The key difference between the turboshaft and previously discussed engines is that not only the turbine drives the compressors, but also the shaft is connected to a *gear box* that drives a helicopter's rotor blades. Although the engine shaft rotates about the horizontal axis, the gear box contains a sequence of gears that transform that motion to a rotation about the vertical axis as required by a helicopter main rotor.

_____ (Guess)

_____ (Guess)

Notes

[1] 1903 年发明飞机的美国莱特兄弟。

[2] 1939 年德国第一架 Heinkel He 178 喷气式飞机试飞成功，其涡轮喷气发动机由 Hans von Ohain 博士设计。

[3] XP-59A (贝尔 XP-59A “Airacomet”) 是美国第一种喷气式战斗机，尽管 XP-59A 在“二战”期间没有在战场上服役的经历，但它为美军提供了喷气式飞机使用、维护和保养的宝贵数据和经验。

[4] P-3 Orion (P-3 猎户座) 是美国洛克希德-马丁公司 1950 年发展出的海上反潜巡逻机。Tu-95 (“北约”给予的代号为熊 (Bear)，是苏联图波列夫设计局 (Tupolev) 所研制，是当代全世界唯一仍服役中的大型四涡轮螺旋桨发动机，用于远程战略轰炸机、空射飞弹发射平台、海上侦察机，以及军用客机。

III Comprehension of Text A

1. Complete the following outline of the text by supplying the missing information.

1) Airplane engines can be classified into _____ types:

(1) _____ engine;

(2) _____ engine which can be further divided into _____, _____, _____, and _____.

2) Discuss the applications of the different types of airplanes classified above.

(1) The modern aircraft equipped with piston engine(s) is _____.



- (2) Turboprop engines are often used in airplanes for _____ .
- (3) Turbojet engines are widely used in _____ .
- 3) Identify the types of engines in Fig. 2.3.

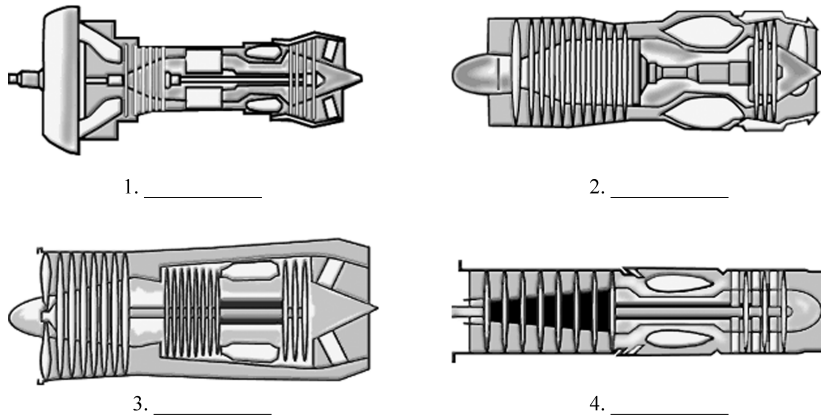

Fig. 2.3

2. Answer the following questions without referring back to the text.

- (1) What are the same basic principles for the operation of different jet engines?
- (2) Do you know the thrust-vector motor? What is the difference between this motor and other jet engines?

IV Vocabulary Development

1. Translate into Chinese the following words or phrases from the text.

- (1) reached their zenith (Para. 3)
- (2) in-line cylinders (Para. 4)
- (3) radial configuration (Para. 4)
- (4) alternate fuels (Para. 5)
- (5) a generic name (Para. 9)
- (6) commuter aircraft (Para. 14)
- (7) significant drawback (Para.15)
- (8) subsonic flight (Para. 15)

2. Complete each of the following sentences by filling in the blank with a word you select from the box. Change the form where necessary. (You can use a word from the box more than once.)

combustion	reciprocate	alternate
chamber	rotate	distinct
thrust	generic	external
accelerate	compact	drawback



- (1) The only _____ of this project is that it costs too much.
- (2) The internal affairs of any state, whether it's big or small, do not allow of _____ interference.
- (3) One should see the processes of growth in _____ and somewhat separable stages.
- (4) My _____ knows my role really well, she's almost better than me.
- (5) Position the bulb socket in the lamp and _____ clockwise.
- (6) Environment protection is more and more important with the _____ of industrialization.
- (7) Incomplete _____ is the principal source of man-made carcinogens.
- (8) After he invented the new drilling machine, honors were _____ upon him.
- (9) In the domain of athletics, _____ accessory has now become vital equipment.
- (10) She drives a decade-old _____ car and shops at discount stores.
- (11) Due to the heavy workload, they decide to _____ with the work.
- (12) This, in turn, would lead us and our partners to _____ a comprehensive and coordinated manner.
- (13) Crop _____ makes a balanced demand on the fertility of the soil.
- (14) The pace of monetary easing also looks set to _____.
- (15) Both plans have drawbacks, says John Smith of the _____ of Commerce.

3. Aeronautical terms: Translate the following terms into Chinese. And then try to explain them in English.

- (1) reciprocating internal-combustion engine
- (2) multistage compressor
- (3) combustion chamber
- (4) turbojet, turbofan, turboprop, and ramjet
- (5) rotating blades
- (6) compressor
- (7) piston (engine)
- (8) mixer
- (9) low-bypass ratio and high-bypass ratio
- (10) propeller

V Group Work

Questions for discussion.

- (1) What is the most advanced type of engine for the fighter today?
- (2) What type of engine is used in Boeing 787? Tell your group members the advantages of the engine if possible.



Text B Aircraft Engine Placement

I Pre-Reading Task

1. Fill in the blanks in Fig. 2.4 with technical terms for engine components.

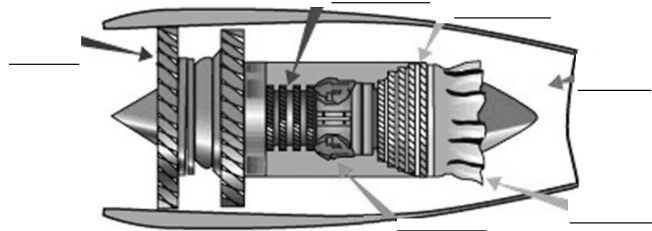

Fig. 2.4

2. What factors should be considered in engine placement? (You can list the factors in Chinese if you can't in English.)

II While-Reading Task

Guess the meaning of each italicized word or phrase in the text and put it down in Chinese in the corresponding blank.

1 Engines may be placed in the wings, on the wings, above the wings, or suspended on pylons below the wings. They may be mounted on the aft fuselage, on top of the fuselage, or on the sides of the fuselage. Wherever the *nacelles* are placed, the detailed spacing with respect to wing, tail, fuselage, or other nacelles is crucial.

2 Wing-mounted engines

3 Engines buried in the wing root have minimum parasite drag and probably minimum weight. Their inboard location minimizes the *yawing moment* due to asymmetric thrust after engine failure. However, they pose a threat to the basic wing structure in the event of a blade or turbine disk failure, make it very difficult to maximize inlet efficiency, and make accessibility for maintenance more difficult. If a larger diameter engine is desired in a later version of the airplane, the entire wing may have to be redesigned. Such installations also eliminate the flap in the region of the engine exhaust, thereby reducing $C_{Lmax}^{[1]}$.

4 For all of these reasons, this approach is no longer used, although the first commercial jet, the deHavilland Comet, had wing-root mounted engines.

Word Tips & Meaning Guessing

n. 短舱; 吊舱

_____ (Guess)